

Cyclic duality for slice and orbit 2-categories

John Boiquaye^a, Philipp Joram^b and Ulrich Krähmer^c

^aDepartment of Mathematics, University of Ghana, Botanical Gardens Road, Legon, GA-489-9348, P.O. Box LG 62, Accra, Ghana

^bTallinna Tehnikaülikool, Ehitajate tee 5, 19086 Tallinn, Estonia

^cTechnische Universität Dresden, Institut für Geometrie, 01062 Dresden, Germany

Abstract

The self-duality of the paracyclic category is extended to the homotopy categories of a certain class of (2,1)-categories. These generalise the orbit category of a group and are associated to suitable self-dual preorders equipped with a presheaf of groups and a cosieve. The slice 2-category of equidimensional submanifolds of a compact manifold without boundary is a particular case, and for S^1 , one recovers cyclic duality. This provides in particular a visualisation of the results of Böhm and Ştefan on the topic.

Communicated by: Boris Tsyan.

Received: 19th June, 2022. Accepted: 18th October, 2024.

MSC: 18N50; 18G45; 19D55.

Keywords: Cyclic category, duplacial category, orbit category, 2-group, crossed module, slice 2-category.

1. Introduction

1.1 Slice 2-categories This article is about embeddings of subobjects, their deformations, and complements. More concretely, we fix a (2,1)-category \mathcal{C} and assume throughout the article:

Assumption 1. *All 1-cells in \mathcal{C} are monic.*

Thus a *subobject* of an object $T \in \mathcal{C}_0$ is by definition an isomorphism class $[x]$ of an object $x \in (\mathcal{C}/T)_0$ in the *slice category* of \mathcal{C} over T , that is, of the preorder of all 1-cells in \mathcal{C} with codomain T with the preorder relation

$$x \leq y \Leftrightarrow \exists f \in \mathcal{C}_1 : x = yf,$$

see e.g. [ML98, Section V.7] or [Lur09, Section 6.1.6].

Email addresses: jboiquaye@ug.edu.gh (Boiquaye)
philipp.joram@taltech.ee (Joram)
ulrich.kraehmer@tu-dresden.de (Krähmer)

© Boiquaye, Joram and Krähmer, 2024, under a Creative Commons Attribution 4.0 International License.
DOI: 10.21136/HS.2024.09

The *slice 2-category* \mathcal{C}/T records further information about the subobjects of T : its objects are 1-cells with codomain T , and its 1-cells $x \rightarrow y$ are 2-cells $\phi: x \Rightarrow z$ in \mathcal{C} with $z \leq y$; think of a deformation of a subobject $[x]$ to a subobject $[z]$ contained in $[y]$. Its 2-cells are 2-cells in \mathcal{C} that deform the target object $[z]$ inside $[y]$ (see Definition 2.2), so in the *homotopy category* $\text{ho}(\mathcal{C}/T)$ (Definition 2.4) such final perturbations of the target $[z]$ get identified.

1.2 Orbit 2-categories For many \mathcal{C} , the ordinary slice category over T is self-dual, with the dual x° of an object representing some form of complement of $[x]$ in T . The question we are interested in is:

Question. When does a self-duality of $((\mathcal{C}/T)_0, \leq)$ lift to $\text{ho}(\mathcal{C}/T)$?

This was triggered by the following example that we will return to in Section 1.3 below, where we provide details and definitions:

Example 1.1. In the (2,1)-category \mathbf{Mfd}^1 of embeddings of compact 1-dimensional manifolds (Definition 2.6), all ordinary slice categories are self-dual. The homotopy category $\text{ho}(\mathbf{Mfd}^1/[0, 1])$ is a model of the *simplicial category* hence is not self-dual. In contrast, $\text{ho}(\mathbf{Mfd}^1/S^1)$ is a model of the *paracyclic category* which is self-dual.

The aim of our paper is to provide sufficient conditions for the existence of a lift of the duality which are all satisfied in the above example.

First of all, we assume that the self-duality of $((\mathcal{C}/T)_0, \leq)$ is equivariant with respect to the natural action of the group $\text{Aut}(T)$ of invertible 1-cells $T \rightarrow T$:

Assumption 2. We are given a map $(\mathcal{C}/T)_0 \rightarrow (\mathcal{C}/T)_0$, $x \mapsto x^\circ$ such that

$$[x^\circ] = [x], \quad [(gx)^\circ] = [g(x^\circ)], \quad x \leq y \Leftrightarrow y^\circ \leq x^\circ$$

holds for all $x, y \in (\mathcal{C}/T)_0$ and $g \in \text{Aut}(T)$.

Such a self-duality gives rise to a subrelation \ll of \leq which is an $\text{Aut}(T)$ -*cosieve* in $((\mathcal{C}/T)_0, \leq)$, i.e. which is closed under the $\text{Aut}(T)$ -action and under postcomposition (Definition 4.1, Proposition 4.2). In $\mathcal{C} = \mathbf{Mfd}^d$, $x \ll y$ means that $[x]$ is contained in the interior of $[y]$.

We will show that if all $x \in (\mathcal{C}/T)_0$ satisfy a suitable form of the *homotopy extension property* (Assumptions 3 and 4 in Section 4, where this is discussed in full detail) and admit an abstract version of *tubular neighbourhoods* (Assumption 5 therein), then the answer to our question is affirmative. More precisely, we prove the theorem stated below. Therein, expressions such as γy and $y\xi$ denote the horizontal composition of the 2-cell id_y with 2-cells γ respectively ξ , and we abbreviate

$$G := \bigcup_{g \in \text{Aut}(T)} \mathcal{C}_2(\text{id}_T, g).$$

We defer all further discussion of the theorem to the main body of the paper. In particular, Examples 3.17, 3.25, 3.35, and 4.8 explain our intuition behind the technical assumptions made and translate them for $\mathcal{C} = \mathbf{Mfd}^d$ and T a manifold with empty boundary into standard results in differential topology:

Theorem 1.2. Let \ll be an $\text{Aut}(T)$ -*cosieve* in $((\mathcal{C}/T)_0, \leq)$ and assume that:

1. $\text{id}_T^\circ \ll \text{id}_T$,

2. given 1-cells $f, h: X \rightarrow Y$, $y: Y \rightarrow T$ in \mathcal{C} , and $\phi: yf \Rightarrow yh$, there exists $\xi: f \Rightarrow h$ with $\phi = y\xi$ if and only if

$$\forall u \ll y^\circ \exists \gamma \in G: (\gamma u = u \text{ and } \gamma y f = \phi),$$

3. for all $u \ll y^\circ, v \ll y^\circ$ there exists $\tau: \text{id}_T \Rightarrow t$ in G and $r \ll y$ with $\tau u = u$, $\tau v = v$, and $[tr] = [y]$.

Then $^\circ$ lifts to an $\mathbf{Aut}(T)$ -equivariant self-duality on $\text{ho}(\mathcal{C}/T)$.

We present the above theorem as a special case of a more general self-duality result: let \mathcal{G} be a (strict) 2-group, A be the group of its 1-cells, and G be its source group (see Section 3.1 for these notions). Then we associate a \mathcal{G} -category \mathcal{I}_s to any A -equivariant presheaf s of subgroups of G on an A -preorder (S, \leq) (Proposition 3.11). When S is the poset of all subgroups of $A = G$ itself and s is the identity, then \mathcal{I}_s is the dual of the *orbit category* of G (Example 3.13, see [tD87, Section I.10] for more information). When the A -preorder is self-dual and \ll is an A -cosieve satisfying Condition (3) in the theorem above, then \mathcal{I}_s gets upgraded to a (2,1)-category with a self-dual homotopy category (Proposition 3.31, Corollary 3.34). The remaining assumptions of our theorem are there to imply $\text{ho}(\mathcal{C}/T) \cong \text{ho}(\mathcal{I}_{s_{\mathcal{C}/T}})$ as $\mathbf{Aut}(T)$ -categories, where $\mathcal{G} = \mathbf{Aut}(T)$ is the automorphism 2-group of T (Corollary 3.34, Example 3.35).

We are not aware of a reference that considers this exact type of (2,1)-category and refer to them as *orbit 2-categories*. Studying other examples and applications might be an interesting topic for future research, as there are many applications of classical orbit categories in equivariant algebraic topology, see e.g. [Wan82, Brö71, BGPT97] and in particular [Elm83], or the more algebraically motivated articles [PYn14, LL15, Web08, Ber17, So01], as well as [MP15].

1.3 Cyclic duality The motivation for this article lies in homological and homotopical algebra. The categories of chain complexes and of simplicial objects are not self-dual – applying contravariant functors yields cochain complexes respectively cosimplicial objects. So by construction, the category of mixed complexes (chain and cochain complexes, same underlying graded module, no compatibility between boundary and coboundary map assumed) is self-dual. Building on the seminal work of Connes ([Con83], see also [Con94, Appendix 3.A]), Dwyer and Kan [DK85] extended the Dold-Kan correspondence to this setting and called the corresponding homotopical objects and the governing index category \mathbf{K} *duplicial*. The self-duality of \mathbf{K} also descends to Connes’ *cyclic category* $\mathbf{\Lambda}$ which is a quotient, and extends to the *paracyclic category* $\mathbf{\Lambda}^\circ$ which is a localisation:

Definition 1.3. The categories $\mathbf{\Delta} \subset \mathbf{K} \subset \mathbf{\Lambda}^\circ$ are defined as follows:

1. The objects are the natural numbers $0, 1, 2, 3, \dots$
2. The morphisms $f: n \rightarrow m$ are the maps $\mathbb{Z} \rightarrow \mathbb{Z}$ satisfying
 - (a) $i \leq j \Rightarrow f(i) \leq f(j)$ for all i, j ,
 - (b) $f(j + n + 1) = f(j) + m + 1$ for all j ,
 - (c) $f(0) \geq 0$ (in \mathbf{K} and $\mathbf{\Delta}$),
 - (d) $f(n) \leq m$ (in $\mathbf{\Delta}$).

The *cyclic dual* of $f: n \rightarrow m$ is the morphism $f^\circ: m \rightarrow n$ given by

$$f^\circ(i) := \max\{j \mid -f(-j) \leq i\}.$$

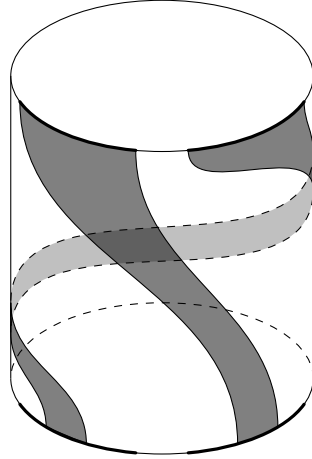

Figure 1: The cyclic operator $1 \rightarrow 1$ in $\text{ho}(\mathbf{Mfd}^1/S^1)$.

See [Con83, DK85, GJ93, FT87, Elm93] for some original references for these definitions, and for example [NS18, p381] and [AMR17, Remark 1.27] for some recent work which mentions cyclic duality. Note, however, that the classical cyclic duality $\mathbf{\Lambda}^\infty \cong (\mathbf{\Lambda}^\infty)^{\text{op}}$ considered in all these references with the exception of [DK85] does not restrict to \mathbf{K} . The above one appears in [DK85, p585] (see also [KK11, Section 4.2]) and is in contrast to the classical one involutive (i.e. we have $f^\infty = f$).

Böhm and Ştefan [BS12] explored the self-duality of $\mathbf{\Lambda}^\infty$ further from the perspective of the bar construction. Our focus is different: we describe $\mathbf{\Lambda}^\infty$ and $\mathbf{\Delta}$ in a unified way in which we can point exactly at the reason why the one is self-dual and the other is not. Both are (skeletal subcategories of) $\text{ho}(\mathcal{C}/T)$ for suitable \mathcal{C} and T . For $\mathbf{\Delta}$ we are looking at $\mathbf{Mfd}^1/[0, 1]$ (Example 2.10), while for $\mathbf{\Lambda}^\infty$ it is \mathbf{Mfd}^1/S^1 (Example 2.9), and the latter is self-dual as S^1 has empty boundary.

We also find the resulting visualisation of $\mathbf{\Lambda}^\infty$ clarifying in several ways. In the standard description, the object n of $\mathbf{\Lambda}^\infty$ gets visualised as $n + 1$ points on S^1 . We replace these by tubular neighbourhoods, which is anyway natural in many settings, e.g. the study of the cyclic homology of DG algebras. Furthermore, the fact that the objects of $\mathbf{\Lambda}^\infty$ are self-dual, $n^\circ = n$, is seen to be in a sense coincidental – the complement of $n + 1$ intervals in S^1 happens to be again $n + 1$ intervals. These are isotopic to the original ones, but in higher-dimensional manifolds T , a submanifold $[x]$ and the closure $[x^\circ]$ of its complement are in general not diffeomorphic.

Most importantly to us, this provides a spatial view on the results of Böhm and Ştefan. Their main aim was to conceptually explain cyclic duality in the setting of Hopf-cyclic (co)homology [HKRS04, Kay11, CM99, Cra02]. They show (see [BS12, Theorem 4.7]) that the simplicial object resulting from the bar construction associated to a comonad S_l and coefficients that they denote by \sqcup, \sqcap becomes paracyclic in the presence of a second comonad S_r , a comonad distributive law $\Psi: S_l S_r \Rightarrow S_r S_l$, and Ψ -(op)coalgebra structures i, w on the coefficients. In our visualisation, this corresponds to gluing the end points of the interval $[0, 1]$ in which the simplicial object is realised to the end points of a second interval in order to obtain a circle S^1 , and the second comonad S_r lives on the dark side of the moon.

The string diagrams in [BS12] can now be seen as planar projections of our depiction of morphisms in $\mathbf{\Lambda}^\infty$ in which we draw the track of a point in S^1 under an isotopy on a cylinder.

In particular, Figure 1 depicts the cyclic operator $t_1: \mathbb{Z} \rightarrow \mathbb{Z}$, $t_1(j) = j + 1$, acting on the object $1 \in \mathbf{A}^\infty$. The natural transformation w corresponds to the track of an interval passing from the front to the back of the cylinder and the distributive law Ψ corresponds to two tracks crossing in the planar projection, while in the spatial resolution one of them runs down the front of the cylinder and the other one the back. Finally, the natural transformation i is where the track from the back reappears on the front of the cylinder.

The remainder of this article is divided into three sections. In the first, we provide some definitions from the theory of slice 2-categories, and discuss the example \mathbf{Mfd}^d of embeddings of compact d -dimensional manifolds. In the second, we develop parts of a general theory of orbit 2-categories associated to certain presheaves of groups on a preorder. Throughout, the guiding examples of preorders are (ordinary) slice categories, but we also discuss a few group-theoretic examples in order to demonstrate the scope of the concepts. In the final section we focus on \mathcal{C}/T and discuss the assumptions of our main theorem in detail.

Throughout the paper, we suppress all set-theoretic problems, so we tacitly assume all categories to be as small as required. Readers who are concerned about the application to manifolds should restrict to submanifolds of \mathbb{R}^{2d} . Similarly, we focus on strict 2-categories.

Acknowledgements. It is a pleasure to thank David Reutter for pointing out to us the article [AMR17]. J.B. is supported by UG Carnegie BANGA-Africa Project, P.J. by the Estonian Research Council grant PSG749, and U.K. by the DFG grant KR 5036/2-1.

2. Slice 2-categories

This section contains background material on (2,1)-categories (see e.g. [JY21] for further information). We recall in particular the definition of the homotopy category $\mathrm{ho}(\mathcal{C}/T)$ of a slice 2-category and discuss in some detail the example of the (2,1)-category \mathbf{Mfd}^d of embeddings of compact d -dimensional manifolds with 2-cells given by isotopies.

2.1 (2,1)-categories Throughout, \mathcal{C} is a strict (2,1)-category, that is, the composition of 1-cells as well as both the vertical and the horizontal composition of 2-cells is strictly associative, and all 2-cells are invertible. In addition, we assume that all 1-cells are monic. The set of 1-cells between objects $X, Y \in \mathcal{C}_0$ is denoted by $\mathcal{C}_1(X, Y)$; 1-cells are denoted by lower case Roman letters and their composition is written as concatenation. The set of 2-cells between $f, g \in \mathcal{C}_1(X, Y)$ is denoted by $\mathcal{C}_2(f, g)$; 2-cells are denoted by lower case Greek letters, and their vertical respectively horizontal compositions by $\alpha \circ \beta$ respectively $\alpha\beta$. The identity 1-cell in $\mathcal{C}_1(X, X)$ is denoted by id_X ; analogously, the identity 2-cell in $\mathcal{C}_2(f, f)$ is denoted by id_f . The vertical inverse of $\alpha: f \Rightarrow g$ will be denoted by $\alpha^*: g \Rightarrow f$, so $\alpha \circ \alpha^* = \mathrm{id}_g$ and $\alpha^* \circ \alpha = \mathrm{id}_f$. We denote the source and target maps $\mathcal{C}_2 \rightarrow \mathcal{C}_1$ and $\mathcal{C}_1 \rightarrow \mathcal{C}_0$ both by \mathfrak{s} respectively \mathfrak{t} . Horizontal composition of 2-cells with identity 1-cells is called *left-* respectively *right-whiskering*, and we write $f\xi := \mathrm{id}_f \xi$ respectively $\xi g := \xi \mathrm{id}_g$, if no confusion arises.

Remark 2.1. Recall that a 2-cell $\alpha: f \Rightarrow g$ is horizontally invertible if and only if $f, g: X \rightarrow Y$ are invertible as 1-cells: a straightforward computation shows (see e.g. [KR21, Lemma 7]) that

the horizontal inverse $\alpha^{-1}: f^{-1} \Rightarrow g^{-1}$ of α is given by

$$\alpha^{-1} = g^{-1}\alpha^*f^{-1}$$

and the vertical inverse $(\alpha^{-1})^*: g^{-1} \Rightarrow f^{-1}$ of α^{-1} is

$$(\alpha^{-1})^* = g^{-1}\alpha f^{-1}.$$

We will also frequently use the fact that in this case, we can express the vertical composition with another 2-cell only using horizontal compositions: if $\delta: g \Rightarrow h$ is another 2-cell, then we have

$$\delta \circ \alpha = \delta \text{id}_{g^{-1}\alpha}.$$

This can be verified by algebraic manipulation:

$$\begin{aligned} \delta \circ \alpha &= (\delta \circ \alpha) \text{id}_{\text{id}_X} \\ &= (\delta \circ \alpha)((\alpha^{-1})^* \circ \alpha^{-1}) \text{id}_f \\ &= ((\delta(\alpha^{-1})^*) \circ (\alpha\alpha^{-1})) \text{id}_f \\ &= ((\delta(\alpha^{-1})^*) \circ \text{id}_{\text{id}_Y}) \text{id}_f \\ &= \delta(\alpha^{-1})^* \text{id}_f = \delta \text{id}_{g^{-1}\alpha}. \end{aligned} \tag{1}$$

However, such computations become evident when using the graphical calculus of string diagrams:

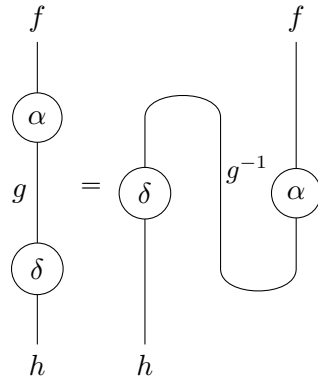

2.2 Slice categories In ordinary category theory, the slice category of a category over some object T has as objects morphisms $x: X \rightarrow T$, and as morphisms commutative triangles:

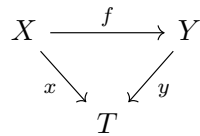

For (2,1)-categories \mathcal{C} , there is the following generalisation in which the equality $x = yf$ is replaced with a 2-cell $x \Rightarrow yf$:

Definition 2.2. The *slice 2-category* over an object $T \in \mathcal{C}_0$ is the (2,1)-category \mathcal{C}/T with the following data:

1. The objects are 1-cells $x: X \rightarrow T$ of \mathcal{C} .
2. 1-cells between objects $x: X \rightarrow T$ and $y: Y \rightarrow T$ are pairs (f, ϕ) consisting of a 1-cell $f: X \rightarrow Y$ and a 2-cell $\phi: x \Rightarrow yf$.

3. The composition of 1-cells $\phi: x \Rightarrow yf$ and $\psi: y \Rightarrow zg$ is given by $(g, \psi)(f, \phi) := (gf, \psi f \circ \phi)$.
4. 2-cells between $\phi: x \Rightarrow yf$ and $\psi: x \Rightarrow yg$ are 2-cells $\xi: f \Rightarrow g$ such that

$$\psi = y\xi \circ \phi \tag{2}$$

5. Vertical and horizontal composition of 2-cells in \mathcal{C}/T is defined as the vertical (respectively horizontal) composition in \mathcal{C} .

We depict the 1-cell (f, ϕ) as follows:

$$\begin{array}{ccc} X & \xrightarrow{f} & Y \\ & \searrow x \quad \phi \Rightarrow \quad \swarrow y & \\ & & T \end{array} \tag{3}$$

See [JY21, Definition 7.1.1(3)] for a diagrammatic depiction of the *ice cream cone condition* (2).

Remark 2.3. As we focus on (2,1)-categories in which all 1-cells $x: X \rightarrow T$ are monic, the 2-cell ϕ which is part of a 1-cell $(f, \phi): x \rightarrow y$ in \mathcal{C}/T uniquely determines the 1-cell f . We denote the latter by f_ϕ and simply write ϕ for (f_ϕ, ϕ) .

2.3 Homotopy categories Instead of just forgetting the 2-cells, one can construct an ordinary category out of a (2,1)-category \mathcal{C} by identifying 1-cells if they are related by a 2-cell:

Definition 2.4. We call $f, g \in \mathcal{C}_1$ *homotopy equivalent* and write $f \sim_h g$ if there exists a 2-cell $\alpha: f \Rightarrow g$. The *homotopy category* $\text{ho}(\mathcal{C})$ of \mathcal{C} is the category with objects $\text{ho}(\mathcal{C})_0 := \mathcal{C}_0$ and morphisms

$$\text{ho}(\mathcal{C})_1(X, Y) := \mathcal{C}_1(X, Y) / \sim_h . \tag{4}$$

Note that [JY21] calls $\text{ho}(\mathcal{C})$ the classifying category of \mathcal{C} , see Example 2.1.27 therein.

Remark 2.5. As we assume all 1-cells in \mathcal{C} to be monic, the objects of \mathcal{C}/T represent the *subobjects* of $T \in \mathcal{C}_0$. By definition, these are equivalence classes $[x]$ with $x: X \rightarrow T, y: Y \rightarrow T$ being equivalent if and only if there is an invertible 1-cell $f: X \rightarrow Y$ such that $x = yf$. A *homotopy equivalence* between objects $X, Y \in \mathcal{C}_0$ is by definition a pair of 1-cells $f: X \rightarrow Y, g: Y \rightarrow X$ whose classes in $\text{ho}(\mathcal{C})$ are inverses of each other, $fg \sim_h \text{id}_Y, gf \sim_h \text{id}_X$. Thus the isomorphism classes of the objects in \mathcal{C}/T are the *homotopy classes of subobjects* of T .

2.4 Embeddings of manifolds We now define the motivating example of a (2,1)-category for this paper:

Definition 2.6. By the (2,1)-category \mathbf{Mfd}^d of *embeddings of compact d -dimensional manifolds* we mean the following:

1. The objects of \mathbf{Mfd}^d are compact smooth d -dimensional manifolds X with (possibly empty) boundary ∂X , together with the empty manifold \emptyset .
2. A 1-cell in \mathbf{Mfd}^d is an embedding, by which we mean a smooth injective immersion.
3. The composition of 1-cells is the ordinary composition of maps.
4. A 2-cell $f \Rightarrow g$ between embeddings $f, g: X \rightarrow Y$ is an isotopy class $[\phi]$ of isotopies ϕ from f to g , that is, of smooth maps $\phi: [0, 1] \times X \rightarrow Y$ such that the restrictions $\phi(t, -): X \rightarrow Y$ are embeddings and for some $\varepsilon > 0$, we have

$$\phi(t, -) = f, \quad \phi(1 - t, -) = g \quad \forall t \in [0, \varepsilon].$$

5. The horizontal composition of 2-cells is induced by the level-wise composition of isotopies,

$$(\alpha\beta)(t, p) := \alpha(t, \beta(t, p))$$

while the vertical composition is induced by the concatenation of the path $\beta(-, p)$ followed by the path $\alpha(-, \beta(1, p))$, both in Y . The vertical inverse of a 2-cell is taken by reversing the orientation of the corresponding path.

See e.g. [Hir94, p. 111] for further details. Note that we do not make any additional assumptions on the behaviour of embeddings on ∂X ; in particular, we do not assume it embeds X as a neat submanifold in the sense of [Hir94, p. 30]. Note further that the vertical composition of isotopies themselves is not strictly associative; however, since we define 2-cells to be isotopy classes of isotopies, \mathbf{Mfd}^d is indeed a strict 2-category.

2.5 Submanifolds The slice 2-category \mathbf{Mfd}^d/T describes embeddings of manifolds into an ambient manifold T of the same dimension d . For this entire Section 2.5, we fix embeddings $x: X \rightarrow T$ and $y: Y \rightarrow T$.

A 1-cell in $(\mathbf{Mfd}^d/T)_1(x, y)$ is represented by an isotopy

$$\phi: x \Rightarrow yf_\phi$$

in \mathbf{Mfd}^d , where $f_\phi: X \rightarrow Y$ is the unique embedding such that

$$\phi(1, -) = yf_\phi.$$

Note that we are in the situation of Remark 2.3.

To visualise such 1-cells, it is convenient to introduce their track:

Definition 2.7. The *track* of an isotopy ϕ is the smooth map

$$\text{track}(\phi): [0, 1] \times X \rightarrow [0, 1] \times T, \quad (t, p) \mapsto (t, \phi(t, p)).$$

Example 2.8. Figure 2 depicts the track of an isotopy ϕ which represents a 1-cell $[\phi] \in (\mathbf{Mfd}^1/S^1)_1(x, y)$. Recall that we work with isotopy classes of isotopies as 2-cells in \mathbf{Mfd}^d rather than isotopies themselves. The representatives ψ of the class $[\phi]$ are isotopies that are isotopic to ϕ , so they share the embeddings x and y of X respectively Y into S^1 at the top ($t = 0$) respectively bottom ($t = 1$) of the cylinder. The track $\text{track}(\psi)$ differs for $0 < t < 1$ from $\text{track}(\phi)$ by an isotopy

$$\omega: [0, 1] \times [0, 1] \times S^1 \rightarrow [0, 1] \times S^1,$$

so for all $t \in [0, 1], p \in X$, we have

$$\text{track}(\phi)(t, p) = (t, \omega(0, t, p)), \quad \text{track}(\psi)(t, p) = (t, \omega(1, t, p)),$$

and for all $s \in [0, 1], p \in X$, we have

$$\omega(s, 0, p) = x(p), \quad \omega(s, 1, p) = y(p).$$

The vertical composition of 1-cells in \mathbf{Mfd}^1/S^1 can be visualised as stacking such cylinders on top of each other.

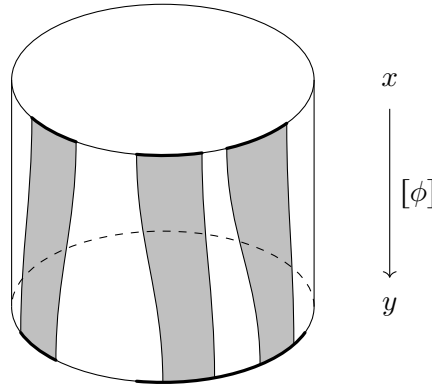

Figure 2: The track of an isotopy representing a 1-cell $[\phi]: x \rightarrow y$ of \mathbf{Mfld}^1/S^1 . $X = \mathfrak{s}(x)$ consists of three copies of the interval $[0, 1]$, $Y = \mathfrak{s}(y)$ of two. The thick lines at the top and bottom mark the subsets $\{0\} \times \text{im } x$ and $\{1\} \times \text{im } y$ of the cylinder $[0, 1] \times S^1$.

Assume now that $[\phi], [\psi]: x \rightarrow y$ are two 1-cells in \mathbf{Mfld}^d/T , and let f_ϕ, f_ψ be the underlying embeddings of X into Y . A 2-cell $[\xi]$ in $(\mathbf{Mfld}^d/T)_2([\phi], [\psi])$ is by definition a 2-cell $[\xi]: f_\phi \Rightarrow f_\psi$ in \mathbf{Mfld}^d , so the representative $\xi: [0, 1] \times X \rightarrow Y$ is an isotopy from f_ϕ to f_ψ satisfying $\psi = (y\xi) \circ \phi$.

Example 2.9. As in Example 2.8 above, we consider $d = 1$ and $T = S^1$. Then the action of a 2-cell ξ can be pictured as in Figure 3. We stress that the action of 2-cells is given by the vertical composition with 1-cells that are not arbitrary but have to be of the form $y\xi$. In Figure 3 this means that for all possible choices of ξ , the (grey) track of $y\xi$ will stay within $\text{im } y \subset S^1$, it can not freely use all of S^1 .

One observes by direct inspection that the paracyclic category $\mathbf{\Lambda}^\infty$ (Definition 1.3) with an initial and a terminal object added can be realised as a skeletal subcategory of $\text{ho}(\mathbf{Mfld}^1/S^1)$: the object n of $\mathbf{\Lambda}^\infty$ can be identified with any embedding of $n + 1$ intervals into S^1 , say

$$x_n: \bigcup_{j=0}^n [j, j + 1/2] \rightarrow S^1, \quad t \mapsto \exp\left(\frac{2\pi it}{n + 1}\right).$$

An isotopy ϕ that represents a 1-cell $x_n \rightarrow x_m$ in \mathbf{Mfld}^1/S^1 defines unique smooth maps $\phi_j: [0, 1] \rightarrow \mathbb{R}$ with

$$\phi(t, x_n(j)) = \exp(2\pi i \phi_j(t)), \quad \phi_j(0) = \frac{j}{n + 1}, \quad j = 0, \dots, n.$$

Now $\phi(1, -) \leq x_m$ implies that there is a unique morphism $f: n \rightarrow m$ in $\mathbf{\Lambda}^\infty$ such that

$$\phi_j(1) \in \left[\frac{f(j)}{m + 1}, \frac{f(j) + 1/2}{m + 1} \right],$$

and the assignment $\phi \mapsto f$ induces an isomorphism between the full subcategory of $\text{ho}(\mathbf{Mfld}^1/S^1)$ consisting of all x_n , $0 \leq n < \infty$, and $\mathbf{\Lambda}^\infty$.

Example 2.10. Analogously, together with the empty embedding and $\text{id}_{[0,1]}$, the simplicial category $\mathbf{\Delta}$ can be realised as a skeletal subcategory of $\text{ho}(\mathbf{Mfld}^1/[0, 1])$.

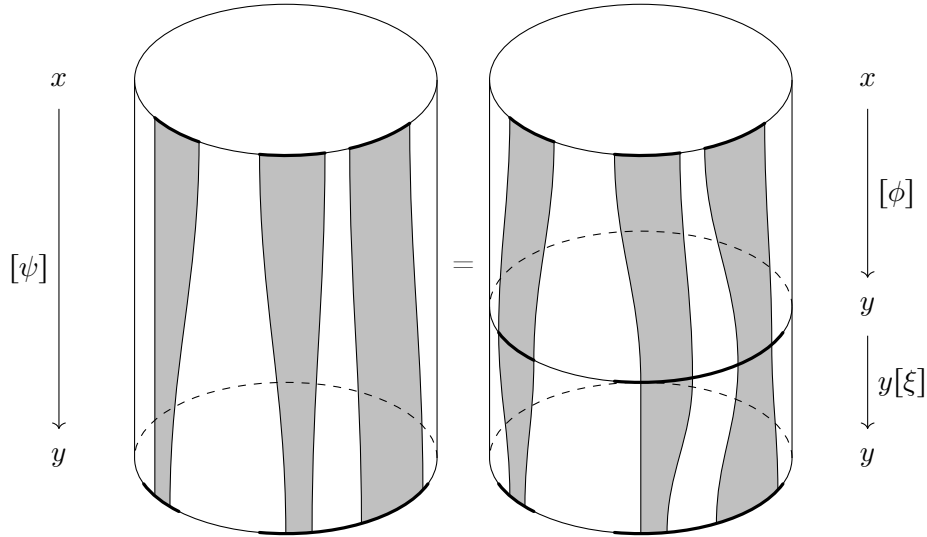

Figure 3: The isotopy $\xi: [0, 1] \times X \rightarrow Y$ between f_ϕ and f_ψ represents a 2-cell in $(\mathbf{Mfd}^1/S^1)_2([\phi], [\psi])$.

Example 2.11. When $d = 3$ and $T = S^3$, then embeddings of a solid torus are knots, and the 1-cells between them are given by isotopies.

Example 2.12. Note that if we view the ordinary slice category as a 2-category in which all 2-cells are identities, then the embedding into \mathcal{C}/T is not necessarily full on 2-cells. That is, there can be nontrivial 2-cells between 1-cells in \mathcal{C}/T of the form (f, id_x) . For example, consider the 2-dimensional manifolds

$$\begin{aligned}
 X &:= \left\{ \begin{pmatrix} a \\ b \end{pmatrix} \in \mathbb{R}^2 \mid \sqrt{a^2 + b^2} \leq 1/5 \right\}, \\
 Y &:= \left\{ \begin{pmatrix} a \\ b \end{pmatrix} \in \mathbb{R}^2 \mid 1/2 \leq \sqrt{a^2 + b^2} \leq 1 \right\}, \\
 T &:= \left\{ \begin{pmatrix} a \\ b \end{pmatrix} \in \mathbb{R}^2 \mid \sqrt{a^2 + b^2} \leq 1 \right\}
 \end{aligned}$$

and the embeddings

$$\begin{aligned}
 f: X &\rightarrow Y, & \begin{pmatrix} a \\ b \end{pmatrix} &\mapsto \begin{pmatrix} a \\ b + 3/4 \end{pmatrix}, \\
 y: Y &\rightarrow T, & \begin{pmatrix} a \\ b \end{pmatrix} &\mapsto \begin{pmatrix} a \\ b \end{pmatrix}, \\
 x &:= yf: X \rightarrow T.
 \end{aligned}$$

The identity 2-cell $\text{id}_x: x \Rightarrow x$ in \mathbf{Mfd}^2 yields a 1-cell $(f, \text{id}_x): x \rightarrow y$ in the slice 2-category \mathbf{Mfd}^2/T . However, there is also a nontrivial 2-cell $\xi: f \Rightarrow f$ in \mathbf{Mfd}^2 which moves the small disc (resp. its embedding) once round the annulus without rotating the disc itself,

$$\xi(t, -) := r_t f r_{-t}: X \rightarrow Y, \quad r_t \left(\begin{pmatrix} a \\ b \end{pmatrix} \right) := \begin{pmatrix} \cos(2\pi t)a + \sin(2\pi t)b \\ -\sin(2\pi t)a + \cos(2\pi t)b \end{pmatrix}.$$

As $y\xi$ is (isotopic to) id_x in \mathbf{Mfd}^2 , ξ satisfies (2) (with $\psi = \phi = \text{id}_x$). It thus defines a nontrivial 2-cell in $(\mathbf{Mfd}^2/T)_2((f, \text{id}_x), (f, \text{id}_x))$. This example also shows that even when y is monic, whiskering on the left with y is not necessarily injective ($\xi \neq \text{id}_f$, but $y\xi = \text{id}_x = y\text{id}_f$).

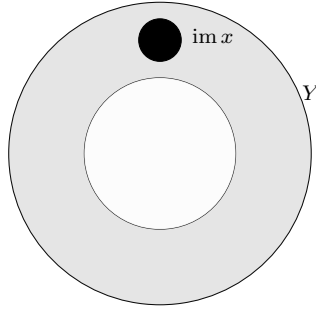

Figure 4: A disc embedded in an annulus

Remark 2.13. The article [AMR17] presents the classical self-duality of $\mathbf{\Lambda}^\infty$ (the one that does not restrict to \mathbf{K}) in a way that is related to our approach, see Remark 1.27 therein. The authors work with stratified spaces rather than smooth manifolds; the analogue of our isotopies are what they call proper constructible bundles over the standard stratified 1-simplex (the latter replaces the interval $[0, 1]$ that parametrises isotopies). The classical duality of $\mathbf{\Lambda}^\infty$ is then viewed as an incarnation of Poincaré duality of stratified 1-dimensional spaces. Roughly speaking, $[n]$ is in this approach represented as a cyclic graph with $n + 1$ vertices and $n + 1$ edges, and the duality is graph duality (edges become vertices, vertices become edges).

3. Cyclic duality for orbit 2-categories

We now study a certain class of 2-thin (2,1)-categories that generalise the orbit category of a group, and formulate sufficient conditions under which their homotopy categories are self-dual. In the subsequent section, we will realise homotopy categories of suitable slice 2-categories in this way and thus prove our main theorem.

3.1 2-groups and crossed modules Throughout the entire Section 3, \mathcal{G} denotes a (strict) 2-group (see e.g. [BL04] for an excellent account on the concept), that is, a (2,1)-category with a single object T in which all 1-cells are invertible. Recall that by the *Brown-Spencer theorem* [BS76], such a 2-group can be equivalently described as follows:

Definition 3.1. A *crossed module* is a pair of group homomorphisms

$$t: G \rightarrow A, \quad a: A \rightarrow \text{Aut}(G)$$

such that

1. for all $h \in A$ and $\gamma \in G$, we have

$$t(a(h)(\gamma)) = ht(\gamma)h^{-1},$$

that is, t is A -equivariant with respect to the action a of A on G and the adjoint action of A on itself, and

2. the *Peiffer identity*

$$\gamma\alpha\gamma^{-1} = a(t(\gamma))(\alpha) \tag{5}$$

holds for all $\alpha, \gamma \in G$.

The crossed module that is associated to (and describes) \mathcal{G} has

$$A := \mathcal{G}_1(T, T),$$

the group of 1-cells in \mathcal{G} , and

$$G := \bigcup_{g \in A} \mathcal{G}_2(\text{id}_T, g),$$

the so-called *source group* of \mathcal{G} (with horizontal composition as group structure, cf. Remark 2.1). The group homomorphism \mathbf{t} is given by the target map in \mathcal{G} , and $\mathbf{a}(h)$ is given by left and right whiskering with h respectively h^{-1} ,

$$\mathbf{a}(h)(\gamma) := h\gamma h^{-1}.$$

Example 3.2. Every group A acts on itself by conjugation, and taking $\mathbf{t} := \text{id}_A$ yields a crossed module. The corresponding 2-group has the group A as its 1-cells and for any $g, h \in A$ a unique 2-cell $g \Rightarrow h$.

3.2 Preorders and actions of 2-groups Recall that a *preorder* is a *thin* category, i.e. one with at most one morphism between any two objects. We denote such a category \mathcal{S} by (S, \leq) , where $S := \mathcal{S}_0$ is the set of objects and \leq is the reflexive and transitive binary relation on S that a morphism $x \rightarrow y$ exists in \mathcal{S} . We will write

$$x \sim y :\Leftrightarrow (x \leq y \text{ and } y \leq x)$$

if $x, y \in S$ are isomorphic in \mathcal{S} .

Definition 3.3. An *A-preorder* is a preorder (S, \leq) with an action of A on S such that $x \leq y \Rightarrow gx \leq gy$ holds for all $x, y \in S$ and $g \in A$.

Example 3.4. The set U_G of all subgroups of G carries a natural action of A and hence defines an *A-preorder* (U_G, \supseteq) .

Definition 3.5. By a *G-presheaf* on an *A-preorder* (S, \leq) we shall mean an *A-equivariant* map of preorders

$$s: (S, \leq) \rightarrow (U_G, \supseteq), \quad x \mapsto G_x,$$

that is, a map such that for all $x, y \in S$ and all $g \in A$, we have

$$G_{gx} = \mathbf{a}(g)(G_x), \quad x \leq y \Rightarrow G_y \subseteq G_x. \tag{6}$$

Here is a toy example:

Example 3.6. Let $A = G$ be any group acting on itself by conjugation (Example 3.2), let S be any *A-set*, and

$$A_x := \{g \in A \mid gx = x\}$$

be the isotropy group of $x \in S$. Then $x \leq y :\Leftrightarrow A_y \subseteq A_x$ turns S into a preorder, and the $\{A_x\}$ form a *G-presheaf* on it.

This generalises as follows to any action of a 2-group on a category:

Example 3.7. Assume that a 2-group \mathcal{G} acts on a category \mathcal{S} . That is, $g \in A$ acts by a functor $\mathcal{S} \rightarrow \mathcal{S}$, and $\gamma: h \Rightarrow g$ in \mathcal{G}_2 by a natural transformation between the functors given by g, h ; more abstractly, we are given a 2-functor $\mathcal{G} \rightarrow \mathbf{Cat}$ which sends the unique object T of \mathcal{G} to \mathcal{S} . If we denote the components of these natural transformations by $\gamma_x: hx \rightarrow gx$, then

$$G_x := \{\gamma \in G \mid \gamma_x = \text{id}_x\}, \quad x \leq y :\Leftrightarrow G_y \subseteq G_x$$

turns $S := \mathcal{S}_0$ into an A -preorder equipped with a \mathcal{G} -presheaf.

In these examples, $x \leq y$ is defined as $G_y \subseteq G_x$, but in general, it is a subrelation. The example that we will use to prove our main result arises in this way as a subobject of one of the above type:

Example 3.8. Let \mathcal{C} be a (2,1)-category, $T \in \mathcal{C}_0$, and $\mathbf{Aut}(T)$ be the *automorphism 2-group* of T , that is, the 2-group of all invertible 1-cells $T \rightarrow T$ and of all 2-cells between these. As a special case of the preceding Example 3.7, $\mathbf{Aut}(T)$ acts on the category underlying the slice 2-category \mathcal{C}/T , with the action gx of $g \in A = \mathbf{Aut}(T)_1$ on $x \in (\mathcal{C}/T)_0$ given by composition, and with $\gamma_x := \gamma x$ (γ whiskered on the right by x). Note that this $\mathbf{Aut}(T)$ -action descends to $\text{ho}(\mathcal{C}/T)$. As above, we set $G_x := \{\gamma \in G \mid \gamma x = x\}$. In this way, we obtain an $\mathbf{Aut}(T)$ -presheaf

$$s_{\mathcal{C}/T}: ((\mathcal{C}/T)_0, \leq) \rightarrow (U_G, \supseteq)$$

on the ordinary slice category of \mathcal{C} over T , so here

$$x \leq y :\Leftrightarrow \exists f \in \mathcal{C}_1 : x = yf.$$

We will show that in good cases, $\text{ho}(\mathcal{C}/T)$ only depends on $s_{\mathcal{C}/T}$.

Remark 3.9. To paint a more complete picture, one could define a 2-category $A\text{-Pro}$ of A -preorders and a 2-category $\mathcal{G}\text{-Psh} = A\text{-Pro}/U_G$ of \mathcal{G} -presheaves. Example 3.7 then becomes part of the definition of a 2-functor $\mathcal{G}\text{-Cat} \rightarrow \mathcal{G}\text{-Psh}$, where $\mathcal{G}\text{-Cat}$ is the 2-category of all categories with an action of \mathcal{G} . Note also that $\mathcal{G}\text{-Psh}$ does not make use of the target map \mathbf{t} of \mathcal{G} , the construction works for all actions of a group A on another group G . However, these remarks are not relevant for our main problem, hence we do not work them out here.

3.3 Orbit categories Let $s: (S, \leq) \rightarrow (U_G, \supseteq)$ be a \mathcal{G} -presheaf.

Remark 3.10. The group G acts via the target map $\mathbf{t}: G \rightarrow A$ on S , and to avoid confusion, we denote this action by

$$\gamma \triangleright x := \mathbf{t}(\gamma)x, \quad \gamma \in G, x \in S.$$

Note that the Peiffer identity (5) implies

$$G_{\gamma \triangleright x} = G_{\mathbf{t}(\gamma)x} = \mathbf{a}(\mathbf{t}(\gamma))(G_x) = \gamma G_x \gamma^{-1}. \tag{7}$$

Here and later, we freely use that the product

$$LR := \{\alpha\beta \in G \mid \alpha \in L, \beta \in R\}$$

turns the power set $P(G)$ of G into a monoid with unit element $\{1\}$. Note that subgroups of G are idempotent elements of $P(G)$. Expressions such as $\gamma G_x \gamma^{-1}$ are a shorthand notation for $\{\gamma\}G_x\{\gamma^{-1}\}$.

As we will explain in Example 3.13 below, the following construction generalises the (dual of the) *orbit category* of a group (see e.g. [tD87, Section I.10]). We will denote the composition of morphisms using \diamond to distinguish it from the product of elements or subsets of G which we continue to denote simply by concatenation. Note also that G/G_x refers to the set of cosets γG_x of the subgroup G_x , not a slice 2-category.

Proposition 3.11. *The following defines a \mathcal{G} -category \mathcal{I}_s :*

1. *The set of objects is $\mathcal{I}_{s,0} := S$.*
2. *The morphism sets are $\mathcal{I}_{s,1}(x, y) := \{\gamma G_x \in G/G_x \mid \gamma \triangleright x \leq y\}$.*
3. *The composition is induced by the product in G ; that is, if $\gamma G_x: x \rightarrow y, \delta G_y: y \rightarrow z$ are morphisms, then*

$$(\delta G_y) \diamond (\gamma G_x) := \delta \gamma G_x.$$

4. *The functor given by $h \in A$ acts on objects via the original action on $\mathcal{I}_{s,0} = S$ and on morphisms by*

$$\mathcal{I}_{s,1}(x, y) \rightarrow \mathcal{I}_{s,1}(hx, hy), \quad \gamma G_x \mapsto (h\gamma h^{-1})G_{hx}.$$

5. *The natural transformation assigned to $\gamma \in G$ has components*

$$\gamma_x := \gamma G_x: x \rightarrow \gamma \triangleright x.$$

Proof. Note first that the composition is equal to the multiplication of subsets of G : $\gamma \triangleright x \leq y$ implies $G_y \subseteq G_{\gamma \triangleright x} = \gamma G_x \gamma^{-1}$ so that

$$\delta G_y \gamma G_x \subseteq \delta \gamma G_x \gamma^{-1} \gamma G_x = \delta \gamma G_x G_x = \delta \gamma G_x = (\delta G_y) \diamond (\gamma G_x).$$

The reverse inclusion holds as $1 \in G_y$, so $\delta \gamma G_x \subseteq \delta G_y \gamma G_x$.

It follows that the definition of $\delta G_y \diamond \gamma G_x$ is independent of the choice of representatives δ, γ and also that \diamond is associative.

Furthermore, $\delta \triangleright y \leq z$ and $\gamma \triangleright x \leq y$ together imply $(\delta \gamma) \triangleright x \leq \delta \triangleright y$, hence $(\delta \gamma) \triangleright x \leq \delta \triangleright y \leq z$. Thus $\delta \gamma G_x$ is a morphism $x \rightarrow z$ in \mathcal{I}_s .

That the \mathcal{G} -action is well-defined is verified straightforwardly – for the naturality of the transformations γ_x use the Peiffer identity (5); note also that γ_x is an isomorphism with inverse $\gamma^{-1} G_{\gamma \triangleright x}$. \square

As an immediate consequence of the definition, we have:

Corollary 3.12. *All $\gamma G_x \in \mathcal{I}_{s,1}(x, y)$ are monic.*

Example 3.13. Consider $G = A$ as in Example 3.2 and

$$s = \text{id}_{U_A}: U_A \rightarrow U_A, \quad x \mapsto A_x = x.$$

In this case, $\mathcal{I}_{\text{id}_{U_A}}$ has the subgroups $x \subseteq A$ as objects, and

$$\mathcal{I}_{s,1}(x, y) = \{gx \in A/x \mid y \subseteq gxg^{-1}\}.$$

Note gx is a coset of the subgroup x . The *orbit category* (see e.g. [tD87, Section I.10]) of A is the category whose objects are the coset spaces A/x , $x \in U_A$, and whose morphisms $g: A/y \rightarrow A/x$ are A -equivariant maps. Such a map g is uniquely determined by its value on $y = 1y \in A/y$, and an element $gx \in A/x$ occurs as such a value if and only if $y \subseteq gxg^{-1}$. Thus \mathcal{I}_s is (isomorphic to) the dual of the orbit category.

This allows us to give the following definition in full generality:

Definition 3.14. We call \mathcal{I}_s° the *orbit category* of s .

We will show later that under the assumptions in our main theorem, the category underlying \mathcal{C}/T is isomorphic to $\mathcal{I}_{s_{\mathcal{C}/T}}$ (recall Example 3.8). This is why we focus on \mathcal{I}_s rather than its dual.

Remark 3.15. Expanding Remark 3.9, the assignment $s \mapsto \mathcal{I}_s$ can be made part of a 2-functor $\mathcal{G}\text{-Psh} \rightarrow \mathcal{G}\text{-Cat}$. The construction from Example 3.7 almost recovers s from \mathcal{I}_s , only the relation \leq is replaced by the potentially weaker one meaning $G_y \subseteq G_x$. So there is a natural transformation from the identity 2-functor on $\mathcal{G}\text{-Psh}$ to the composition of the two constructions. As far as we can see, this is in general not part of a 2-adjunction: starting with any \mathcal{G} -category \mathcal{S} and defining s as in Example 3.7, the morphisms in the resulting \mathcal{G} -category \mathcal{I}_s are generated by the γ_x together with virtual embeddings $x \rightarrow y$ whenever $G_x \supseteq G_y$. These might not correspond to any actual morphisms in \mathcal{S} , and, conversely, there might be morphisms in \mathcal{S} that are entirely unrelated to the \mathcal{G} -action (e.g. when \mathcal{G} is nontrivial but acts trivially on \mathcal{S}). However, our main result suggests that there is a class of well-behaved \mathcal{G} -categories for which the two 2-functors form a split adjunction of suitable 2-categories.

3.4 Self-dual preorders The aim of the remainder of Section 3 is to upgrade the ordinary category \mathcal{I}_s to a (2,1)-category with a self-dual homotopy category. In order to do so, we need to assume the presence of two additional structures on the underlying A -preorders. The first one is an A -equivariant self-duality:

Definition 3.16. An A -self-duality on an A -preorder (S, \leq) is a map

$$S \rightarrow S, \quad x \mapsto x^\circ$$

such that for all $x, y \in S$ and $g \in A$, we have

$$x \sim x^{\circ\circ}, \quad x \leq y \Leftrightarrow y^\circ \leq x^\circ, \quad (gx)^\circ \sim g(x^\circ). \tag{8}$$

Here is the main example that we have in mind:

Example 3.17. Consider $s_{\mathcal{C}/T}$ (Example 3.8) with $\mathcal{C} = \mathbf{Mfd}^d$, so $(\mathcal{C}/T)_0$ consists of all embeddings $x: X \rightarrow T$ of a manifold X into a compact manifold T of the same dimension d . The preorder relation $x \leq y \Leftrightarrow \exists f: x = yf$ means that $\text{im } x \subseteq \text{im } y$, and if T has empty boundary, then the inclusion x° of the closure of the complement $T \setminus \text{im } x$ into T is a $\text{Diff}(T)$ -self-duality.

Bear in mind though that our setting is quite general. In particular, x° is in general not a complement in most of the standard meanings of the word. Here is an example which shows amongst other things that x and x° do not need to be jointly epic:

Example 3.18. Let \mathcal{C} be the (2,1)-category whose objects are the intervals of the form $(-\infty, t]$ and $[s, \infty)$, $s, t \in \mathbb{R}$, plus \emptyset and $T = \mathbb{R}$, whose 1-cells are inclusions (so \mathcal{C} is a preorder and in fact a poset), and all of whose 2-cells are identities (so $G = A$ is trivial). Then

$$[s, \infty)^\circ := (-\infty, s - 1], \quad (-\infty, t]^\circ := [t + 1, \infty)$$

and

$$[s, \infty)^\bullet := (-\infty, s + 1], \quad (-\infty, t]^\bullet := [t - 1, \infty)$$

both define self-dualities on the preorder $((\mathcal{C}/T)_0, \leq)$, but we have

$$\text{im } x \cup \text{im } x^\circ \neq \mathbb{R}, \quad \text{im } x \cap \text{im } x^\bullet \neq \emptyset.$$

Finally, here are two examples of a very different nature:

Example 3.19. Let $G = A$ be any group, viewed as a 2-group as in Example 3.2, and let S be any G -set. Let $H \triangleleft G$ be a normal subgroup and define $G_x := H$ for all $x \in S$ and $x \leq y$ for all $x, y \in S$ (so $x \sim y$ for all $x, y \in S$). This defines a \mathcal{G} -presheaf, and $x^\circ := x$ is a G -self-duality.

Example 3.20. Let again $G = A$ be any group, H, K be normal subgroups, and $S := \{H, K\}$ with trivial G -action. Set $G_x := x$ and $x \leq y \Leftrightarrow G_x \supseteq G_y$. Then $H^\circ := K, K^\circ := H$ defines a G -self-duality.

In this example, G_{x° is not necessarily contained in the centraliser $Z_G(G_x)$, but note that we always have:

Lemma 3.21. *If s is a \mathcal{G} -presheaf and \circ is a self-duality on the underlying A -preorder, then we have*

$$N_G(G_x) = N_G(G_{x^\circ}).$$

In particular, $G_x \subseteq N_G(G_{x^\circ})$.

Proof. By (8) and (7), $G_x = G_{\gamma \triangleright x}$ implies

$$G_{x^\circ} = G_{(\gamma \triangleright x)^\circ} = G_{\gamma \triangleright x^\circ}. \quad \square$$

Corollary 3.22. *$G_x G_{x^\circ} = G_{x^\circ} G_x$ is a subgroup of G . If, in addition, we have $G_x \cap G_{x^\circ} = \{1\}$, then $G_x G_{x^\circ} \cong G_x \times G_{x^\circ}$.*

3.5 Cosieves The second ingredient we use for the (2,1)-upgrade of \mathcal{I}_s is a *cosieve* in the A -preorder underlying s (recall that a cosieve in a category is just a set of morphisms closed under postcomposition with any morphism). This provides an abstract concept of an ‘‘interior’’ of a subobject; like the self-duality it should be compatible with the A -action:

Definition 3.23. A binary relation \ll is an A -cosieve in the A -preorder (S, \leq) if for all $x, y, z \in S$ with $x \ll y$ and all $g \in A$, we have

$$x \leq y, \quad gx \ll gy, \quad y \leq z \Rightarrow x \ll z.$$

Note that this implies:

Lemma 3.24. *If $y \sim z$, then $x \ll y \Leftrightarrow x \ll z$.*

Again, we first consider the example that motivates the definition:

Example 3.25. Consider $s_{\mathbf{Mfd}^d/T}$ (Example 3.8, Example 3.17). Then the relation $x \ll y$ (where $x: X \rightarrow T$ and $y: Y \rightarrow T$ are embeddings of manifolds) that $\text{im } x$ is contained in the interior of $\text{im } y$ (i.e. the boundary of $\text{im } x$ does not intersect the boundary of $\text{im } y$) is a $\text{Diff}(T)$ -cosieve.

Example 3.26. Any self-duality defines a cosieve

$$x \ll_\circ y \Leftrightarrow (x \leq y \text{ and } \langle G_{y^\circ} \cup G_x \rangle = G),$$

where the right hand side denotes the fact that G_{y° and G_x together generate G as a group and one might expect that this canonical choice is the obvious one to use when applying our

main theorem. However, in the preceding Example 3.25 that we are most interested in, this is, a stricter relation than \ll : if $\text{im } x$ is not properly contained in the interior of $\text{im } y$, then it has a nontrivial intersection with $\text{im } y^\circ$, the closure of the complement of $\text{im } y$ in T . Thus this intersection contains at least one point p which is fixed by all $\gamma \in \langle G_{y^\circ} \cup G_x \rangle$ and in particular by their codomains $g = \mathbf{t}(\gamma): T \rightarrow T$. However, for each point in a manifold there is some diffeomorphism that is isotopic to id_T and that moves this point, so $\langle G_{y^\circ} \cup G_x \rangle \subsetneq G$. Therefore, we have $x \ll_\circ y \Rightarrow x \ll y$, but the converse does not hold in general. In particular, if $\text{im } x \subset T = S^1$ is a nonempty proper submanifold, then G_x consists of isotopy classes of isotopies $\gamma: \text{id}_{S^1} \Rightarrow g \in \text{Diff}(S^1)$ with $\gamma x = \text{id}_x$, so g belongs to the subgroup $\text{Diff}(S^1)_x$ of diffeomorphisms that restrict to the identity on $\text{im } x$. Since the complement of $\text{im } x$ is contractible and we consider isotopy classes of isotopies rather than isotopies themselves, such γ are uniquely determined by g . That is, $\mathbf{t}: G_x \rightarrow \text{Diff}(S^1)_x$ is a group isomorphism. So if $x \ll y$ for $\text{im } y \subsetneq S^1$, then $\langle G_{y^\circ} \cup G_x \rangle$ does not contain the 2-cell $\text{id}_{S^1} \Rightarrow \text{id}_{S^1}$ that is represented by the isotopy

$$[0, 1] \times S^1 \rightarrow S^1, \quad (t, e^{2\pi i s}) \mapsto e^{2\pi i(s+t)} \tag{9}$$

that rotates the entire circle once, so we do not have $x \ll_\circ y$.

Here is an abstract algebraic example that illustrates that the behaviour of \ll_\circ can be very different from what one might expect:

Example 3.27. Let $G = A$ be a group viewed as a 2-group (Example 3.2) that acts trivially on a set S . If $\{G_x\}_{x \in S}$ is a family of normal subgroups with $G_x \subseteq G_y \Leftrightarrow x = y$, then we obtain a G -preorder with a \mathcal{G} -presheaf by setting $x \leq y \Leftrightarrow x = y$, and a G -self-duality by setting $x^\circ := x$ for all x . Assume furthermore that for any $x \neq y$, $\langle G_x \cup G_y \rangle = G$. As a concrete example, we can take $G = \mathbb{Z}$, S the set of prime numbers, and $G_x = \langle x \rangle$ the group of all integers divisible by x . Then there are no $x, y \in S$ with $x \ll_\circ y$ at all.

Before we move on to the construction of the (2,1)-category \mathcal{I}_s , we briefly discuss for the example $((\mathcal{C}/T)_0, \leq)$ the close relation between $\text{Aut}(T)$ -cosieves in the $\text{Aut}(T)$ -preorder and cosieves in \mathcal{C} itself:

Proposition 3.28. *If \ll is an $\text{Aut}(T)$ -cosieve in $((\mathcal{C}/T)_0, \leq)$, then*

$$\begin{aligned} \mathcal{S}_\ll &:= \{f \in \mathcal{C}_1 \mid \forall y \in \mathcal{C}_1 : \mathbf{s}(y) = \mathbf{t}(f) \Rightarrow yf \ll y\}, \\ \bar{\mathcal{S}}_\ll &:= \{hf \mid h: Y \rightarrow Z, f: X \rightarrow Y, \text{ and } \exists y: Y \rightarrow T : yf \ll y\}. \end{aligned}$$

are cosieves $\mathcal{S}_\ll \subseteq \bar{\mathcal{S}}_\ll$ in \mathcal{C} . Conversely, if \mathcal{S} is any cosieve in \mathcal{C} , then

$$x \ll_{\mathcal{S}} y \Leftrightarrow \exists f \in \mathcal{S} : x = yf$$

is an $\text{Aut}(T)$ -cosieve, and we have $\mathcal{S}_\ll_{\mathcal{S}} = \bar{\mathcal{S}}_\ll_{\mathcal{S}} = \mathcal{S}$ as well as

$$x \ll_{\mathcal{S}_\ll} y \Rightarrow x \ll y \Rightarrow x \ll_{\bar{\mathcal{S}}_\ll} y.$$

Proof. Let \ll be an $\text{Aut}(T)$ -cosieve. Given $f: X \rightarrow Y$ in \mathcal{S}_\ll and $h: Y \rightarrow Z$, we need to show $hf \in \mathcal{S}_\ll$, that is, that for all $z: Z \rightarrow T$ we have $zhf \ll z$. To see this, set $y := zh, x := yf = zhf$. Then on the one hand, we have $x = yf \ll y$ by the definition of \mathcal{S}_\ll , and on the other hand $y = zh \leq z$ by the definition of \leq . Since \ll is a cosieve, this implies $x \ll z$ as required. That $\bar{\mathcal{S}}_\ll$ is a cosieve is immediate (it is the cosieve generated by all f with $yf \ll y$ for some y).

Conversely, if \mathcal{S} is a cosieve in \mathcal{C} and $x \ll_{\mathcal{S}} y$ holds, then we have $x \leq y$ and $gx \ll_{\mathcal{S}} gy$ (as $gx = gyf \Leftrightarrow x = yf$ for all $g \in \text{Aut}(T)$). Also if $y \leq z$ with $y = zh$ for some $h: Y \rightarrow Z$, then $x = yf = zhf$ and as $hf \in \mathcal{S}$ (\mathcal{S} is a cosieve), $x \ll_{\mathcal{S}} z$. So $\ll_{\mathcal{S}}$ is an $\text{Aut}(T)$ -cosieve.

We have

$$\mathcal{S}_{\ll_{\mathcal{S}}} = \{f: X \rightarrow Y \mid \forall y: Y \rightarrow T \exists \tilde{f} \in \mathcal{S} : yf = y\tilde{f}\}$$

and as all 1-cells are monic, we evidently have $\mathcal{S}_{\ll_{\mathcal{S}}} = \mathcal{S}$. Similarly, $\bar{\mathcal{S}}_{\ll_{\mathcal{S}}} = \mathcal{S}$. Conversely, $x \ll_{\mathcal{S}_{\ll_{\mathcal{S}}}} y \Rightarrow x \ll y$ follows immediately from

$$x \ll_{\mathcal{S}_{\ll_{\mathcal{S}}}} y \Leftrightarrow \exists f : (x = yf \text{ and } \forall \tilde{y}: Y \rightarrow T : \tilde{y}f \ll \tilde{y}).$$

The implication $x \ll y \Rightarrow x \ll_{\bar{\mathcal{S}}_{\ll_{\mathcal{S}}}} y$ follows analogously from

$$x \ll_{\bar{\mathcal{S}}_{\ll_{\mathcal{S}}}} y \Leftrightarrow \exists f : (x = yf \text{ and } \exists \tilde{y}, h, g : \tilde{y}g \ll \tilde{y}, f = hg),$$

just take $g = f, \tilde{y} = y, h = \text{id}_{S(y)}$. □

Here is an example of an A -cosieve that is not of the form $\ll_{\mathcal{S}}$:

Example 3.29. Let \mathcal{C} be the (2,1)-category of all sets whose 1-cells are either identity maps or maps which are injective but not surjective, and whose 2-cells are all identities. If T is any set, 1-cells in \mathcal{C}/T are given by the relation $x \leq y \Leftrightarrow \text{im } x \subseteq \text{im } y$; the 2-cells are all identities. The group $\text{Aut}(T)$ is trivial, all 1-cells in \mathcal{C} are monic, and any $t \in T$ defines a cosieve

$$x \ll y : \Leftrightarrow x \leq y \text{ and } t \in \text{im } y \setminus \text{im } x,$$

but \mathcal{S}_{\ll} (and hence $\ll_{\mathcal{S}_{\ll}}$) is empty, while $\bar{\mathcal{S}}_{\ll}$ consists of all 1-cells that are not identities.

Note, however, that in our main example, \ll is of the form $\ll_{\mathcal{S}}$:

Example 3.30. If $\mathcal{C} = \mathbf{Mfld}^d$, then the set of all embeddings $X \rightarrow Y$ of a manifold X into the interior of Y is a cosieve, hence \ll from Example 3.25 is a $\text{Diff}(T)$ -cosieve given by a cosieve in \mathcal{C} .

3.6 Orbit 2-categories We now show that the choice of an A -cosieve \ll and of an A -self-duality \circ upgrades \mathcal{I}_s to a (2,1)-category which is *2-thin* (i.e. contains at most one 2-cell between any two 1-cells):

Proposition 3.31. *Let $s: (S, \leq) \rightarrow (U_G, \supseteq)$ be a \mathcal{G} -presheaf, \circ be an A -self-duality, and \ll be an A -cosieve. Then we have:*

1. *The relation*

$$\gamma G_x \equiv \varepsilon G_x : \Leftrightarrow (\forall u \in S : u \ll y^\circ \Rightarrow G_u \cap \varepsilon G_x \gamma^{-1} \neq \emptyset)$$

is an equivalence relation on the morphism set $\mathcal{I}_s(x, y)$.

2. *Interpreting \equiv as a 2-cell turns \mathcal{I}_s into a (2,1)-category.*

3. *The \mathcal{G} -action on \mathcal{I}_s induces a \mathcal{G} -action on $\text{ho}(\mathcal{I}_s)$.*

Proof. For all $u \in S$, we have $1 \in G_u \cap \gamma G_x \gamma^{-1}$, hence

$$\gamma G_x \equiv \gamma G_x.$$

Next, if $\alpha \in G_u \cap \varepsilon G_x \gamma^{-1}$, then $\alpha^{-1} \in G_u \cap \gamma G_x \varepsilon^{-1}$, so

$$\gamma G_x \equiv \varepsilon G_x \Rightarrow \varepsilon G_x \equiv \gamma G_x.$$

Finally, if $\alpha \in G_u \cap \varepsilon G_x \gamma^{-1}$ and $\beta \in G_u \cap \rho G_x \varepsilon^{-1}$, then we obtain $\beta \alpha \in G_u \cap \rho G_x \gamma^{-1}$, so

$$\gamma G_x \equiv \varepsilon G_x, \varepsilon G_x \equiv \rho G_x \Rightarrow \gamma G_x \equiv \rho G_x.$$

So \equiv is an equivalence relation, and if we interpret it as a 2-cell, there is a (necessarily unique and associative) vertical composition of 2-cells (which in a sense is induced by the product in G), there is an identity 2-cell for each 1-cell γG_x (represented by 1), and all 2-cells are invertible.

Up to here no properties of \ll have been used. However, they are required to establish a horizontal composition of 2-cells $\gamma G_x \equiv \varepsilon G_x$ and $\delta G_y \equiv \lambda G_y$ for two other 1-cells $\delta G_y, \lambda G_y: y \rightarrow z$.

We have to show $\delta \gamma G_x \equiv \lambda \varepsilon G_x$. To do so, assume $u \in S$ with $u \ll z^\circ$. Then as $\delta G_y \equiv \lambda G_y$, there exists an element

$$\mu \in G_u \cap \lambda G_y \delta^{-1}.$$

Since εG_x is a 1-cell $x \rightarrow y$, we have $\varepsilon \triangleright x \leq y \Rightarrow G_y \subseteq \varepsilon G_x \varepsilon^{-1}$, so we also have

$$\mu \in G_u \cap \lambda \varepsilon G_x \varepsilon^{-1} \delta^{-1}. \quad (10)$$

Furthermore, as δG_y is a 1-cell $y \rightarrow z$, we have $\delta \triangleright y \leq z \Rightarrow z^\circ \leq \delta \triangleright y^\circ$. Thus $u \ll z^\circ$ implies $u \ll \delta \triangleright y^\circ \Rightarrow \delta^{-1} \triangleright u \ll y^\circ$ and as $\gamma G_x \equiv \varepsilon G_x$, there exists some

$$\alpha \in G_{\delta^{-1} \triangleright u} \cap \varepsilon G_x \gamma^{-1},$$

which means

$$\delta \alpha \delta^{-1} \in G_u \cap \delta \varepsilon G_x \gamma^{-1} \delta^{-1}.$$

In combination with (10) we conclude

$$\mu \delta \alpha \delta^{-1} \in G_u \cap \lambda \varepsilon G_x \gamma^{-1} \delta^{-1},$$

so this set is not empty as we had to show in order to establish the horizontal composition $\delta \gamma G_x \Rightarrow \lambda \varepsilon G_x$ of $\gamma G_x \Rightarrow \varepsilon G_x$ with $\delta G_y \Rightarrow \lambda G_y$.

Due to the uniqueness of 2-cells, the horizontal composition is automatically associative and satisfies the exchange law.

Last but not least, the action of A on \mathcal{I}_s defined in Proposition 3.11 descends to $\text{ho}(\mathcal{I}_s)$, since for all $h \in A$, we have

$$\gamma G_x \equiv \varepsilon G_x \Leftrightarrow (h \gamma h^{-1} G_{hx} \equiv (h \varepsilon h^{-1}) G_{hx},$$

simply conjugate all of $G_u \cap \varepsilon G_x \gamma^{-1} \neq \emptyset$ by h . Similarly, the natural transformations $\gamma_x = \gamma G_x$ descend to $\text{ho}(\mathcal{I}_s)$. \square

Example 3.32. We keep extending Examples 3.17 and 3.25 with $\mathcal{C} = \mathbf{Mfd}^d$, T a compact d -dimensional manifold without boundary. Two 1-cells $\gamma G_x, \varepsilon G_x: x \rightarrow y$ in $\mathcal{I}_{s_{\mathcal{C}/T}}$ are represented by isotopy classes of isotopies $\gamma: \text{id}_T \Rightarrow g, \varepsilon: \text{id}_T \Rightarrow e$ with $\text{im } gx \subseteq \text{im } y, \text{im } ex \subseteq \text{im } y$. To distinguish this from the generic case, we write here \blacktriangleright instead of \triangleright ; recall that $\gamma \blacktriangleright x = gx, \varepsilon \blacktriangleright x = ex, y \leq z \Leftrightarrow \text{im } y \subseteq \text{im } z$. The group G_x contains the isotopies whose restriction γx to $\text{im } x$ is (isotopy to) the constant isotopy with value $\text{id}_{\text{im } x}$. So we can identify γG_x via the assignment

$$\gamma G_x \mapsto \gamma x: x \Rightarrow gx \quad (11)$$

with the restriction of $\gamma: \text{id}_T \Rightarrow g$ to $\text{im } x$. The coset γG_x defines a 1-cell $\gamma G_x: x \rightarrow y$ whenever $\text{im } gx \subseteq \text{im } y$. Now $\gamma G_x \equiv \varepsilon G_x$ means that for all submanifolds $\text{im } u \subseteq T$ that are disjoint from $\text{im } y$ (i.e. $u \ll y^\circ$) there exists a 2-cell $\alpha: \text{id}_T \Rightarrow a$ for some diffeomorphism $a: T \rightarrow T$ which is on the one hand in G_u , that is, the restriction of α to $\text{im } u$ is constantly equal to the identity,

$$\alpha(t, p) = p \quad \forall t \in [0, 1], p \in \text{im } u \subset T \setminus \text{im } y.$$

At the same time, $\alpha \in \varepsilon G_x \gamma^{-1} = \varepsilon \gamma^{-1} G_{\gamma \triangleright x}$ means that αx is a 2-cell that composes with γx to εx . The upshot is that $\gamma G_x \equiv \varepsilon G_x$ means that for any choice of submanifold $\text{im } u$ that is disjoint from $\text{im } y$, we find an isotopy that fixes $\text{im } u$ pointwise and deforms the embedding $gx: X \rightarrow T$ inside the complement of $\text{im } u$ to $ex: X \rightarrow T$.

3.7 Lifting of self-dualities Let $s: (S, \leq) \rightarrow (U_G, \supseteq)$ be a \mathcal{G} -presheaf and (S, \leq) be self-dual. If $\gamma G_x: x \rightarrow y$ is a morphism in \mathcal{I}_s , then $\gamma \triangleright x \leq y$. As \circ is a self-duality, $y^\circ \leq (\gamma \triangleright x)^\circ = \gamma \triangleright x^\circ$, hence $\gamma^{-1} \triangleright y^\circ \leq x^\circ$ and there is a morphism $\gamma^{-1} G_{y^\circ}: y^\circ \rightarrow x^\circ$. However, in general this does not lead to a self-duality of \mathcal{I}_s itself, since the assignment $\gamma G_x \mapsto \gamma^{-1} G_{y^\circ}$ is not well-defined unless $G_x \subseteq G_{y^\circ}$. What we will show now is that on $\text{ho}(\mathcal{I}_s)$, we obtain a somewhat satisfactory resolution of this issue.

One easily verifies that $\gamma G_x = \varepsilon G_x$ implies $\gamma^{-1} G_{y^\circ} \equiv \varepsilon^{-1} G_{y^\circ}$, but in general, $\gamma G_x \equiv \varepsilon G_x$ does not necessarily imply $\gamma^{-1} G_{y^\circ} \equiv \varepsilon^{-1} G_{y^\circ}$. We now formulate a technical condition that ensures it does; we will explain in Example 3.35 that this is an abstract replacement of the existence of a tubular neighbourhood of a submanifold.

Proposition 3.33. *Assume that \circ is an A -self-duality, \ll is an A -cosieve, and that for all $b, c, d \in S$ we have*

$$\begin{aligned} & (c \ll b^\circ \text{ and } d \ll b^\circ) \\ \Rightarrow & \exists \rho \in G_c \cap G_d, a \in S : (\rho \triangleright a \sim b \text{ and } a \ll b). \end{aligned} \tag{12}$$

If $\gamma G_x \equiv \varepsilon G_x: x \rightarrow y$ in \mathcal{I}_s , then we have $\gamma^{-1} G_{y^\circ} \equiv \varepsilon^{-1} G_{y^\circ}: y^\circ \rightarrow x^\circ$.

Proof. We need to show

$$\begin{aligned} \gamma^{-1} G_{y^\circ} \equiv \varepsilon^{-1} G_{y^\circ} & \Leftrightarrow \forall v \ll x : G_v \cap \varepsilon^{-1} G_{y^\circ} \gamma \neq \emptyset \\ & \Leftrightarrow \forall v \ll x : \varepsilon G_v \gamma^{-1} \cap G_{y^\circ} \neq \emptyset. \end{aligned}$$

We are going to apply (12) with

$$b = y^\circ, \quad c = \gamma \triangleright v, \quad d = \varepsilon \triangleright v,$$

so we need to show $(\gamma \triangleright v) \ll y^\circ$ and $(\varepsilon \triangleright v) \ll y^\circ$. To do so, recall once more that $\gamma G_x, \varepsilon G_x: x \rightarrow y$ are 1-cells, so $(\gamma \triangleright x) \leq y, (\varepsilon \triangleright x) \leq y$. Together with $v \ll x \Rightarrow \gamma \triangleright v \ll \gamma \triangleright x$ and $v \ll x \Rightarrow \varepsilon \triangleright v \ll \varepsilon \triangleright x$ we conclude $\gamma \triangleright v \ll y, \varepsilon \triangleright v \ll y$, and now we can use $y^\circ \sim y$ and Lemma 3.24.

So by (12), there are $\rho \in G, a \in S$ satisfying

$$\rho \in G_{\gamma \triangleright v} \cap G_{\varepsilon \triangleright v}, \quad \rho \triangleright y^\circ \sim a, \quad a \ll y^\circ.$$

Now we use $\gamma G_x \equiv \varepsilon G_x$ with $u := a$. This shows that

$$G_a \cap \varepsilon G_x \gamma^{-1} = G_{\rho \triangleright y^\circ} \cap \varepsilon G_x \gamma \neq \emptyset$$

which implies (conjugate with ρ^{-1} and use $v \ll x \Rightarrow v \leq x \Rightarrow G_x \subseteq G_v$)

$$G_{y^\circ} \cap \rho^{-1} \varepsilon G_v \gamma^{-1} \rho \neq \emptyset.$$

As ρ and hence ρ^{-1} are both in $G_{\gamma \triangleright v}$ and $G_{\varepsilon \triangleright v}$ we finally have

$$\begin{aligned} \rho^{-1} \varepsilon G_v \gamma^{-1} \rho &= \rho^{-1} G_{\varepsilon \triangleright x} \varepsilon \gamma^{-1} \rho \\ &= G_{\varepsilon \triangleright v} \varepsilon \gamma^{-1} \rho \\ &= \varepsilon \gamma^{-1} G_{\gamma \triangleright v} \rho \\ &= \varepsilon \gamma^{-1} G_{\gamma \triangleright v} \\ &= \varepsilon G_v \gamma^{-1}. \square \end{aligned}$$

Corollary 3.34. *Under the assumptions of Proposition 3.33, $\text{ho}(\mathcal{I}_s)$ is a self-dual category, with the dual of $[\gamma G_x]: x \rightarrow y$ given by*

$$[\gamma G_x]^\circ := [\gamma^{-1} G_{y^\circ}]: y^\circ \rightarrow x^\circ.$$

Example 3.35. For $s_{\text{Mfld}^d/T}$, (Example 3.32), b, c, d correspond to submanifolds $B := \text{im } b, C := \text{im } c, D := \text{im } d \subseteq T$ with

$$B \cap C = B \cap D = \emptyset,$$

so C, D are both contained in the interior of $T \setminus B$ (as $c \ll b^\circ, d \ll b^\circ$). Condition (12) asserts the existence of an isotopy $\rho: \text{id}_T \Rightarrow r$ for some diffeomorphism $r: T \rightarrow T$ such that ρc is constantly id_C and ρd is constantly id_D while ρ shrinks B to a manifold $A = \text{im } a$ contained in the interior of B which is however diffeomorphic to B via r . To obtain such an isotopy, choose a Riemannian metric on T . Extend the outward normal vectors of length 1 on $B \subset T$ to a vector field on all of T that is only supported on a small neighbourhood of ∂B disjoint from C and D (using e.g. a partition of 1 and bump functions). Following the inverse flow of this vector field for times in a sufficiently small closed time interval yields ρ (or rather its vertical inverse ρ^*).

4. Application to slice 2-categories

Our main theorem follows more or less immediately from the results above, but we discuss its assumptions and our main example in more detail, as well as the canonical choice of the relation \ll . Throughout, we make Assumptions 1 and 2, and $A = \text{Aut}(T), G, G_x, \blacktriangleright, \leq$ and $s_{\mathcal{C}/T}$ are as in Examples 3.8 and 3.32.

4.1 The interior of a subobject The theory developed in Section 3 crucially relies on the choice of an $\text{Aut}(T)$ -cosieve with certain properties. This is an auxiliary structure though, neither the category $\text{ho}(\mathcal{C}/T)$ nor the resulting self-duality on it depends on this choice.

As we will discuss in the next subsection, the central assumption of our theorem is a strong form of the homotopy extension property well-studied in algebraic and differential topology. We now define an $\text{Aut}(T)$ -cosieve \ll that is adapted to the formulation of this assumption:

Definition 4.1. If $u \leq v$, then we set

$$u \ll v \Leftrightarrow \forall \xi: x \Rightarrow z \exists \gamma \in G_u: \mathfrak{t}(x) = \mathfrak{s}(v^\circ) \Rightarrow \gamma v^\circ x = v^\circ \xi.$$

As we will explain in Example 4.8 below, this is consistent with the notation introduced for the special case \mathbf{Mfd}^d/T in Example 3.25 above. The interpretation derived from this example is that a subobject $[u]$ of T that is contained in a subobject $[v]$ is in the *interior* of $[v]$ if and only if any 2-cell ξ which only acts in the complement $[v^\circ]$ of $[v]$ can be extended to a 2-cell $\gamma: \text{id}_T \Rightarrow g$ for which $g \in \text{Aut}(T)$ and γ is constantly the identity on $[u]$, $\gamma u = u$.

Let us verify that Definition 4.1 indeed defines an $\text{Aut}(T)$ -cosieve:

Proposition 4.2. \ll is an $\text{Aut}(T)$ -cosieve in $((\mathcal{C}/T)_0, \blacktriangleright, \leq)$.

Proof. Assume $u \ll v$. Then $u \leq v$ holds by definition, say $u = vb$. If $d \in \text{Aut}(T)$, then we have $du \leq dv$ as $du = dvb$. Also, the domain of $(dv)^\circ = dv^\circ$ agrees with the domain of v° . Hence if $\xi: x \Rightarrow z$ is any 2-cell in \mathcal{C} between 1-cells x, z whose codomain is $\mathfrak{t}(x) = \mathfrak{t}((dv)^\circ) = \mathfrak{t}(v^\circ)$, then by assumption, there exists $\gamma \in G$ with $\gamma u = u$ and $\gamma v^\circ x = v^\circ \xi$. Then $\eta := d\gamma d^{-1}$ satisfies

$$\eta(du) = d\gamma d^{-1}du = d\gamma u = du$$

and

$$\eta(dv)^\circ x = \eta(dv^\circ)x = d\gamma d^{-1}dv^\circ x = d\gamma v^\circ x = dv^\circ \xi = (dv)^\circ \xi.$$

Thus $du \ll dv$. Similarly, if $v \leq w$, say $v = wc$, then we have $u = vb = wcb \leq w$ and $w^\circ \leq v^\circ$, say $w^\circ = v^\circ l$. Furthermore, if $\psi: m \rightarrow n$ is a 2-cell between 1-cells m, n with codomain

$$\mathfrak{t}(m) = \mathfrak{s}(w^\circ) = \mathfrak{s}(l),$$

then $\xi := l\psi: x \Rightarrow z$, $x := lm$, $z := ln$, is a 2-cell and the target $\mathfrak{t}(x) = \mathfrak{s}(v^\circ)$, so there exists $\gamma \in G_u$ with

$$\gamma w^\circ m = \gamma v^\circ lm = \gamma v^\circ x = v^\circ \xi = v^\circ l\psi = w^\circ \psi.$$

So $u \ll w$ as we had to show. \square

So far, this subsection has not made any assumptions on \mathcal{C} and T , but what we need to demand is that the converse of Definition 4.1 holds, that is, that we can characterise the image of the maps $\mathcal{C}_2 \rightarrow \mathcal{C}_2, \xi \mapsto e\xi$ in terms of \ll :

Assumption 3. If $x, z: X \rightarrow E$, $e: E \rightarrow T$, and $\phi: ex \Rightarrow ez$, then

$$(\exists \xi: x \Rightarrow z: \phi = e\xi) \Leftrightarrow (\forall u \ll e^\circ \exists \gamma \in G_u: \gamma ex = \phi).$$

To be clear: the implication \Rightarrow holds by definition of \ll , what we assume is \Leftarrow . In the next subsection, this assumption will in combination with Assumption 4 formulated there enable us to identify \mathcal{C}/T with the orbit 2-category described in the previous section. The essential step in this is to observe that the two assumptions imply that each 1-cell in \mathcal{C} is a cofibration, cf. Remark 4.7. However, this does not follow from the assumptions made so far alone. In particular, it may happen that \ll and Assumption 3 are trivial:

Example 4.3. As a variation of our standard example, consider the $(2,1)$ -category $\mathcal{C} = \mathbf{Riem}^d$ of d -dimensional compact Riemannian manifolds with isometric embeddings as 1-cells and isotopy classes of isotopies ϕ for which all $\phi(t, -)$ are isometric embeddings as 2-cells. When $d = 1$ and $T = S^1$ with its standard metric, then $\text{Aut}(T)$ is the group of rotations, and for $u: U \rightarrow T$, G_u consists just of the identity unless $U = \emptyset$. It is now easily verified that $u \ll v$ only holds when $U = \emptyset$ or $v: V \rightarrow T$ is an automorphism of $V = T$, and that Assumption 3 is trivially satisfied. Assmption 4, however, will not be satisfied in this example.

Assumption 3 enters the proof of our theorem in the following way:

Proposition 4.4. *There exists a 2-cell ξ between 1-cells $\gamma x, \varepsilon x$ in \mathcal{C}/T with $x \in (\mathcal{C}/T)_0, \gamma, \varepsilon \in G$ if and only if $\gamma G_x \equiv \varepsilon G_x$.*

Proof. If $\gamma: \text{id}_T \Rightarrow g$, then we have

$$\begin{aligned} \varepsilon x = y\xi \circ \gamma x &\Leftrightarrow \varepsilon x \circ (\gamma x)^* = y\xi \\ &\Leftrightarrow \varepsilon x \circ \gamma^* x = y\xi \\ &\Leftrightarrow (\varepsilon \circ \gamma^*)x = y\xi \\ &\Leftrightarrow (\varepsilon \circ g\gamma^{-1})x = y\xi \\ &\Leftrightarrow \varepsilon g\gamma^{-1}x = y\xi \\ &\Leftrightarrow \varepsilon\gamma^{-1}gx = y\xi. \end{aligned}$$

Now apply Assumption 3 with $\phi = \varepsilon\gamma^{-1}gx$. □

4.2 The homotopy extension property As we will show now, the backbone of our main theorem is that the objects in $(\mathcal{C}/T)_0$ are *cofibrations*, which in the language we have developed means that all objects have a nonempty interior: as id_T is terminal in $((\mathcal{C}/T)_0, \leq)$, id_T° is initial, that is, we have $\text{id}_T^\circ \leq v$ for all $v \in (\mathcal{C}/T)_0$, so the following implies $\text{id}_T^\circ \ll v$ for all v .

Assumption 4. $\text{id}_T^\circ \ll \text{id}_T^\circ$.

So explicitly, we assume that for all $x, z \in (\mathcal{C}/T)_0$, we have

$$\forall \xi: x \Rightarrow z \exists \gamma \in G_{\text{id}_T^\circ} : \gamma x = \xi. \quad (13)$$

This implies:

Proposition 4.5. *If $g \sim_h \text{id}_T$, then g is invertible.*

Proof. If $\xi: \text{id}_T \Rightarrow g$ is a 2-cell, then by Assumption 4, $\xi \in G_{\text{id}_T^\circ} \subseteq G$, so its codomain is invertible. □

More importantly, if $\gamma G_x: x \rightarrow y$ is a morphism in $\mathcal{I}_{s_{\mathcal{C}/T}}$, then by definition, we have $\gamma \blacktriangleright x \leq y$, so there exists a unique (all 1-cells are monic) $f: x \rightarrow y$ with $\gamma \blacktriangleright x = yf$, and with $\phi := \gamma x$ we obtain a morphism $x \rightarrow y$ in \mathcal{C}/T , viewed as an ordinary category. Thus we obtain a functor

$$I_{\mathcal{C}/T}: \mathcal{I}_{s_{\mathcal{C}/T}} \rightarrow \mathcal{C}/T, \quad (\gamma G_x: x \rightarrow y) \mapsto ((f, \gamma x): x \rightarrow y)$$

which is the identity map on objects and is easily seen to be compatible with the $\mathbf{Aut}(T)$ -actions. It is by the definition of G_x faithful, and by (13) and Proposition 4.4, we in fact finally obtain:

Proposition 4.6. *The functor $I_{\mathcal{C}/T}$ is an isomorphism and induces an isomorphism of $\mathbf{Aut}(T)$ -categories $\text{ho}(\mathcal{C}/T) \cong \text{ho}(\mathcal{I}_{s_{\mathcal{C}/T}})$.*

More precisely, “ \Rightarrow ” in Assumption 3 implies that $I_{\mathcal{C}/T}^{-1}$ extends to a 2-functor $\mathcal{C}/T \rightarrow \mathcal{I}_{s_{\mathcal{C}/T}}$ and if in addition “ \Leftarrow ” holds, this induces an isomorphism $\text{ho}(\mathcal{C}/T) \cong \text{ho}(\mathcal{I}_{s_{\mathcal{C}/T}})$.

Remark 4.7. A 1-cell $x: X \rightarrow T$ in a 2-category is a *cofibration* (see e.g. [LR20]) if for all $\phi: sx \Rightarrow v, s: T \rightarrow V, v: X \rightarrow V$ there exists $w: T \rightarrow V$ with $v = wx$ and $\rho: s \Rightarrow w$ with $\phi = \rho x$. As we assume all 1-cells are monic, \mathcal{C}/T remains unchanged if we discard all objects V in \mathcal{C} without a 1-cell $V \rightarrow T$, and then Assumption 4 simply says that all 1-cells in \mathcal{C} are cofibrations. In many examples, there is a *path space object* V^I in \mathcal{C} that comes equipped with source and target 1-cells $s, t: V^I \rightarrow V$ (think of a space of paths $[0, 1] \rightarrow V$ in a space V), and 2-cells $\phi: r \Rightarrow v$ between 1-cells $r, v: X \rightarrow V$ correspond to 1-cells $p: X \rightarrow V^I$ with $r = sp, v = tp$. Then the cofibration property becomes depicted by the following standard diagram

$$\begin{array}{ccc} X & \xrightarrow{p} & V^I \\ \downarrow x & \nearrow \exists! & \downarrow \partial_0 \\ T & \xrightarrow{s} & V. \end{array}$$

Example 4.8. In $\mathcal{C} = \mathbf{Mfld}^d$, id_T° is the empty embedding of the empty set, and Assumptions 3 and 4 hold if and only if T has no boundary. We refer e.g. [Hir94, Theorem 8.1.6] for the proof of the homotopy extension property; see also the recent post [Goo18] by Goodwillie who discusses the uniqueness of the extensions. Reformulated in our language, he therein points out that G_x and hence γG_x is not just a path-connected, but a contractible topological space. In this sense, the extension γ of a given ϕ to all of T is from a homotopy-theoretic point of view unique. The non-uniqueness of the extension was the reason why we introduced the auxiliary tool of the orbit 2-category $\mathcal{I}_{\mathcal{C}/T}$. Its 1-cells are the cosets γG_x rather than the representatives γ themselves, and that is why $\mathcal{I}_{\mathcal{C}/T}$ is faithful by definition.

Once it is established that 2-cells between $x, z: X \rightarrow T$ extend to all of T , it is easily seen that Assumption 3 holds and that $u \ll v$ as defined in Definition 4.1 means that $\text{im } u$ is contained in the interior of $\text{im } v$ (Example 3.25): indeed, if we have

$$\text{im } x, \text{im } z \subseteq E \subsetneq T, \quad U = \text{im } u \subsetneq V = T \setminus E,$$

then there is a tubular neighbourhood of ∂E that is disjoint from U . Using a partition of 1 we obtain a smooth bump function $b \in C^\infty(T)$ with value 1 on E and value 0 on U ; now any extension $\eta \in G$ of an isotopy $\phi: x \Rightarrow z$ can be replaced by $\gamma \in G_u$ given by

$$\gamma(t, p) := \eta(tb(t), p), \quad t \in [0, 1], p \in T$$

with $\gamma(t, p) = p$ for all t and $p \in U$ (as in Example 3.32). Conversely, if such an extension of ϕ exists, then ϕ only acts inside $T \setminus U$. So if U can be chosen arbitrarily in $T \setminus E$, ϕ is of the form $e\xi$.

4.3 Tubular neighbourhoods To complete the proof of our theorem, we need to show that \circ extends to $\mathcal{I}_{\mathcal{C}/T}$, and here we simply assume outright the required condition (12):

Assumption 5. For all $b, c, d \in (\mathcal{C}/T)_0$ with $c \ll b^\circ$ and $d \ll b^\circ$, there are $\rho \in G_c \cap G_d$ and $a \in (\mathcal{C}/T)_0$ with $\rho \blacktriangleright a \sim b$ and $a \ll b$.

The picture we have in mind has already been discussed in Example 3.35: we are given submanifolds $B \subseteq T$ and $C, D \subset T \setminus B$ and then use a tubular neighbourhood of ∂B to replace

B by a slightly smaller but diffeomorphic submanifold $A \subset B$. So Assumption 5 is about an abstract form of tubular neighbourhoods and deformation retracts.

Nowhere in this paper we have assumed that the preorders studied are lattices, i.e. that one can take some form of unions or intersections of subobjects, and in fact in the case of $\mathcal{C} = \mathbf{Mfld}^d$, one can not. However, the union of submanifolds C, D contained in the interior of a submanifold is obviously contained in a slightly larger submanifold E , and if \mathcal{C}/T has this property, then we can use the homotopy extension property to formulate Assumption 5 internally in B :

Example 4.9. Assume that in \mathcal{C}/T , there exists for all $c \ll v, d \ll v$ an $e \ll v$ with $c \leq v, d \leq v$. Then Assumption 5 can be reduced to the assumption that for all $b: B \rightarrow T$ there exists an invertible 1-cell $i: B \rightarrow B$ with $a := bi \ll b$ and $i \sim_h \text{id}_B$, as by Assumption 3 a 2-cell $\iota: i \Rightarrow \text{id}_B$ gives rise to $b\iota: a \Rightarrow b$ which can be extended to a 2-cell $\rho \in G_e \subseteq G_c \cap G_d$ as in Assumption 5.

To sum up: the assumptions made in the present section are those from our main theorem, which follows from Proposition 4.6 (Assumptions 3 and 4 imply $\text{ho}(\mathcal{C}/T) \cong \text{ho}(\mathcal{I}_{s_{\mathcal{C}/T}})$) in combination with Corollary 3.34 (Assumption 5 implies that $\text{ho}(\mathcal{I}_{s_{\mathcal{C}/T}})$ is self-dual).

References

- [AMR17] David Ayala, Aaron Mazel-Gee, Nick Rozenblyum. Factorization homology of enriched ∞ -categories. arXiv:1710.06414v1.
- [Ber17] Julia E. Bergner. Equivalence of models for equivariant $(\infty, 1)$ -categories. *Glasg. Math. J.*, 59(1):237–253, 2017.
- [BGPT97] R. Brown, M. Golasinski, T. Porter, and A. Tonks. Spaces of maps into classifying spaces for equivariant crossed complexes. *Indag. Math. (N.S.)*, 8(2):157–172, 1997.
- [BL04] John C. Baez and Aaron D. Lauda. Higher-dimensional algebra. V. 2-groups. *Theory Appl. Categ.*, 12:423–491, 2004.
- [Blu07] Andrew J. Blumberg. A discrete model of S^1 -homotopy theory. *J. Pure Appl. Algebra*, 210(1):29–41, 2007.
- [Brö71] Theodor Bröcker. Singuläre Definition der äquivarianten Bredon Homologie. *Manuscripta Math.*, 5:91–102, 1971.
- [BS76] Ronald Brown and Christopher B. Spencer. G -groupoids, crossed modules and the fundamental groupoid of a topological group. *Indag. Math.*, 79(4):296–302, 1976.
- [BŞ12] Gabriella Böhm and Dragoş Ştefan. A categorical approach to cyclic duality. *J. Noncommut. Geom.*, 6(3):481–538, 2012.
- [CM99] Alain Connes and Henri Moscovici. Cyclic cohomology and Hopf algebras. Moshé Flato (1937–1998), *Lett. Math. Phys.* 48(1):97–108, 1999.
- [Con83] Alain Connes. Cohomologie cyclique et foncteurs Ext^n . *C. R. Acad. Sci. Paris Sér. I Math.*, 296(23):953–958, 1983.
- [Con94] Alain Connes. *Noncommutative geometry*. Academic Press, Inc., San Diego, CA, 1994.

- [Cra02] Marius Crainic. Cyclic cohomology of Hopf algebras. *J. Pure Appl. Algebra*, 166(1-2):29–66, 2002.
- [DK85] W. G. Dwyer and D. M. Kan. Normalizing the cyclic modules of Connes. *Comment. Math. Helv.*, 60(4):582–600, 1985.
- [Elm83] A. D. Elmendorf. Systems of fixed point sets. *Trans. Amer. Math. Soc.*, 277(1):275–284, 1983.
- [Elm93] A. D. Elmendorf. A simple formula for cyclic duality. *Proc. Amer. Math. Soc.*, 118(3):709–711, 1993.
- [FT87] B. L. Feĭgin and B. L. Tsygan. Additive K -theory. In *K-theory, arithmetic and geometry (Moscow, 1984–1986)*, volume 1289 of *Lecture Notes in Math.*, pages 67–209. Springer, Berlin, 1987.
- [GJ93] Ezra Getzler and John D. S. Jones. The cyclic homology of crossed product algebras. *J. Reine Angew. Math.*, 445:161–174, 1993.
- [Goo18] Tom Goodwillie. Isotopy extension theorem: how non-unique is ambient isotopy. MathOverflow, 2018. Version: 2018-06-01.
- [Hir94] Morris W. Hirsch. *Differential topology*, volume 33 of *Graduate Texts in Mathematics*. Springer-Verlag, New York, 1994. Corrected reprint of the 1976 original.
- [HKRS04] Piotr M. Hajac, Masoud Khalkhali, Bahram Rangipour, and Yorck Sommerhäuser. Hopf-cyclic homology and cohomology with coefficients. *C. R. Math. Acad. Sci. Paris*, 338(9):667–672, 2004.
- [JY21] Niles Johnson and Donald Yau. *2-dimensional categories*. Oxford University Press, Oxford, 2021.
- [Kay11] Atabey Kaygun. A survey on Hopf-cyclic cohomology and Connes-Moscovici characteristic map. In *Noncommutative geometry and global analysis*, volume 546 of *Contemp. Math.*, pages 171–179. Amer. Math. Soc., Providence, RI, 2011.
- [KK11] Niels Kowalzig and Ulrich Krähmer. Cyclic structures in algebraic (co)homology theories. *Homology Homotopy Appl.*, 13(1):297–318, 2011.
- [KR21] Ulrich Krähmer and Lucia Rotheray. (Weak) incidence bialgebras of monoidal categories. *Glasg. Math. J.*, 63(1):139–157, 2021.
- [LL15] Ran Levi and Assaf Libman. Existence and uniqueness of classifying spaces for fusion systems over discrete p -toral groups. *J. Lond. Math. Soc. (2)*, 91(1):47–70, 2015.
- [LR20] Fosco Loregian and Emily Riehl. Categorical notions of fibration. *Expo. Math.*, 38(4):496–514, 2020.
- [Lur09] Jacob Lurie. *Higher topos theory*, volume 170 of *Annals of Mathematics Studies*. Princeton University Press, Princeton, NJ, 2009.
- [ML98] Saunders Mac Lane. *Categories for the working mathematician*, volume 5 of *Graduate Texts in Mathematics*. Springer-Verlag, New York, second edition, 1998.

- [MP15] Jeffrey C. Morton and Roger Picken. Transformation double categories associated to 2-group actions. *Theory Appl. Categ.*, 30:Paper No. 43, 1429–1468, 2015.
- [NS18] Thomas Nikolaus and Peter Scholze. On topological cyclic homology. *Acta Math.*, 221(2):203–409, 2018.
- [PYn14] Semra Pamuk and Ergün Yalçın. Relative group cohomology and the orbit category. *Comm. Algebra*, 42(7):3220–3243, 2014.
- [Scu02] Laura Scull. Rational S^1 -equivariant homotopy theory. *Trans. Amer. Math. Soc.*, 354(1):1–45, 2002.
- [So01] Jolanta Słomińska. Homotopy decompositions of orbit spaces and the Webb conjecture. *Fund. Math.*, 169(2):105–137, 2001.
- [tD87] Tammo tom Dieck. *Transformation groups*, volume 8 of *De Gruyter Studies in Mathematics*. Walter de Gruyter & Co., Berlin, 1987.
- [Wan82] Stefan Waner. A generalization of the cohomology of groups. *Proc. Amer. Math. Soc.*, 85(3):469–474, 1982.
- [Web08] Peter Webb. Standard stratifications of EI categories and Alperin’s weight conjecture. *J. Algebra*, 320(12):4073–4091, 2008.